

#527 Adjustable Pipe Saddle Support C/W U-Bolt

Finish Hot Dipped Galvanized (HDG), Bare Metal

Material Carbon Steel Saddle, nipple and U-Bolt with cast iron reducing coupling.
Stainless Steel 304SS & 316SS

Approval Complies with MSS SP-58 and SP-69 (Type 37, 38).

Recommended 2 1/2" through 36"

Designed to be used in conjunction with a base stand to support horizontal pipe. Straight cut pipe thread on nipple provides adjustability, U-Bolt secures pipe to saddle.

Specify pipe size, figure number, name and finish.

Base stand ordered separately.

Requires accurate center line of pipe to floor dimension "L".

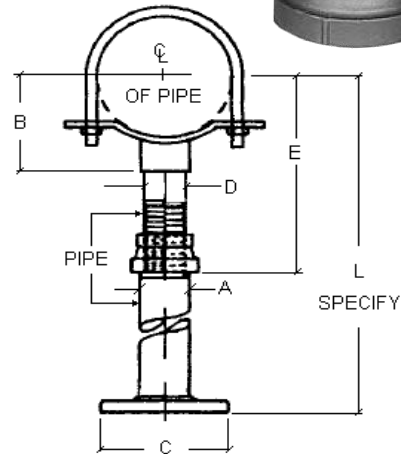
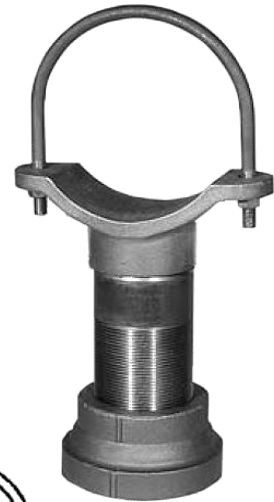

IRON PIPE SIZE	SPECIFICATION DATA				Dimension E		APP'X LBS PER 100	
	A	B	C	D	MIN.	MAX.	COMPLETE	SADDLE ONLY
2 1/2	2 1/2	3 7/16	8	1 1/2	8	13	900	480
3	2 1/2	3 11/16	8	1 1/2	8 1/4	13 1/4	920	500
3 1/2	2 1/2	3 15/16	8	1 1/2	8 1/2	13 1/2	940	520
4	3	4 3/16	10	2 1/2	9 1/4	14	1500	760
5	3	4 13/16	10	2 1/2	10	14 3/4	1665	925
6	3	5 7/16	10	2 1/2	10 1/2	15 1/4	1765	1025
8	3	6 15/16	10	2 1/2	11 3/4	16 1/2	2020	1280
10	3	8 7/16	10	2 1/2	13 1/2	18 1/4	2515	1775
12	3	9 15/16	10	2 1/2	15	19 3/4	2900	2160
14	4	10 15/16	10	3	16 1/4	20 3/4	4920	3800
16	4	12 3/8	10	3	17 3/4	22 1/4	5320	4200
18	6	13 7/8	12	4	19 1/2	24	7080	5100
20	6	15 3/8	12	4	21	25 1/2	10480	8500
24	6	17 15/16	12	4	23 3/4	28 1/4	13000	11000
30	6	21 5/16	12	4	27	31 1/2	17000	15000
32	6	22 1/2	12	4	28 1/4	32 3/4	18100	16100
36	6	24 1/2	12	4	30 1/4	34 3/4	24900	22900